

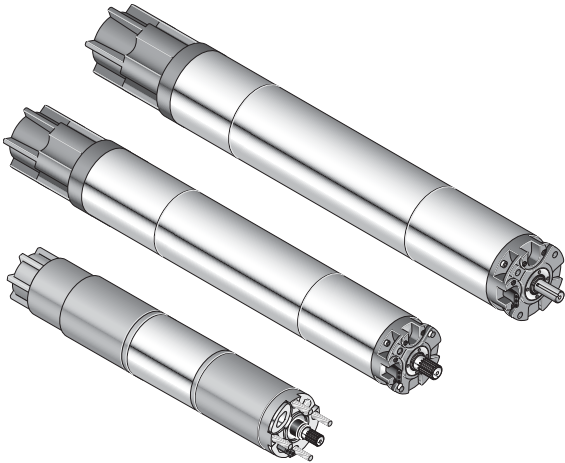

6", 8", 10" and 12" Rewindable Submersible Motors



- Assembly and operation constructions	1
--	---

Franklin Electric Europa GmbH
Rudolf-Diesel-Straße 20
D-54616 Wittlich, Germany
Tel.: +49 (0) 65 71 / 105 0
Fax: +49 (0) 65 71 / 105 520

E-Mail: field-service@franklin-electric.de
Internet: www.franklin-electric.eu



Franklin Electric

EC Declaration of Conformity

Manufacturer: Franklin Electric Europa GmbH
Rudolf-Diesel-Strasse 20
D-54516 Wittlich/Germany

Product: Rewindable Submersible motors

Type Designations: 262..., 263..., 264..., 265..., 266...

The above products are in conformity with the following European Directives:

2006/95/EC (Low Voltage Directive)

and

2004/108/EC (EMC Directive)

Applied harmonized standards: **EN 60034-1**

P. Klippel
Engineering & Quality Manager

15 December 2009

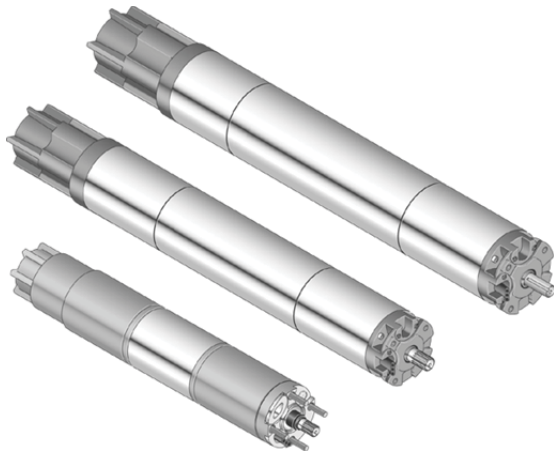

6", 8", 10" and 12" Rewindable Submersible Motors

GB

Assembly and Operating Instructions



Franklin Electric Europa GmbH
Rudolf-Diesel-Straße 20
D-54616 Wittlich, Germany
Tel.: +49 (0) 65 71 / 105 - 0
Fax: +49 (0) 65 71 / 105 - 520

E-Mail: field-service@franklin-electric.de
Internet: www.franklin-electric.eu

Doc.-no.: 308 018 427
Version: February 2011

1 About This Document	2
1.1 Warning notices and warning symbols	2
1.2 Instructions and Highlights	2
2 Safety	3
2.1 Intended use	3
2.2 Target group	3
2.3 General safety instructions	3
3 Storage, Transport, Disposal	4
4 Technical specifications	4
5 Pre-Operation Checks	6
5.1 Check the motor prior to installation	6
5.2 Assembling the motor and pump	8
5.3 Connecting the drop cable	8
5.4 Measuring the insulation resistance	9
5.5 Powering the motor	9
6 Motor Operation	11
6.1 Proper motor cooling	11
6.2 Providing a check valve and level sensor	11
6.3 Switching on the motor	11
6.4 Motor operation with frequency converter	12
6.5 Motor operation with softstarter	12
7 Maintenance and service	12
8 Troubleshooting	12
9 Service	12
10 Appendix	12

© Copyright by Franklin Electric Europa GmbH 2005

All rights in these instructions are reserved – specifically the copying, distribution and translation rights. No part of these instructions shall be reproduced, or processed, copied or distributed using electronic systems or otherwise without the prior permission in writing of Franklin Electric Europa GmbH.

Changes due to technical developments reserved.

1 About This Document

The assembly and operating instructions form an integral part of the rewindable submersible motor and describe its safe, intended use in all operating phases.

- Document Retention** ⇒ Keep the assembly and operating instructions in the immediate vicinity of the motor.
⇒ Hand the assembly and operating instructions over to every subsequent user of the motor.

Application The assembly and operating instructions only apply to the motors described in this booklet.

1.1 Warning notices and warning symbols

Warning notices point out special dangers and indicate the measures that can be taken to avoid the danger. Warning notices come in three levels:

Warning word	Meaning
DANGER	Immediate danger to life and health
WARNING	Possible danger to life and health
CAUTION	Possible danger of slight injury or material damage

Warning notices are built up as follows:



Warning word

Type and source of danger as well as the possible consequences of measures not being observed!

- ⊙ *Forbidden actions.*
 - ⇒ *Measures to avoid the danger.*
-

1.2 Instructions and Highlights

In the assembly and operating instructions we use the following symbols and highlights, for improved legibility and uniform identification.

- Insulation measuring unit (this indicates a listing)
- ☑ Instructions ... observed (this indicates a condition)
- ⇒ Switch off the motor. (this indicates an instruction to take action)
Motor has stopped. (this indicates the result of the action)
- Immediately switch off** the motor... (you can see a highlight in bold here)



Note

Specifically important information is given here. You should observe this information to ensure correct and safe operation of the motor.

2 Safety

This section describes the safety rules which must be observed for the safe use of submersible motors. Possible sources of danger and the relevant safety measures are listed here.

2.1 Intended use

Franklin Electric submersible motors are only intended for integration with a submersible pump in order to drive the relevant pump under water. They must only be put into use if the machine fulfils the provisions of the applicable directives and statutory provisions.

The submersible motors must only be used in clean, highly fluid media, such as drinking or process water.

The following media are not allowed: air, highly flammable, explosive media and wastewater.

Loss of guarantee and exclusion of liability

Franklin Electric shall not be liable for the damage resulting from any further, non-intended use. The risk of such use rests solely with the user.

2.2 Target group

The electrical system must only be installed by professional staff (qualified electrical engineers or electrical machine technicians).

2.3 General safety instructions

The following safety measures must be observed prior to putting the motor into use:

- Do not carry out any other work on the motor other than described in these instructions.
- Only use the motor under water (the motor and the short motor cable must be fully submersed).
- Do not implement any changes or conversions to the motor or its electrical connections.
- Never open the motor.
- Never use the motor in combination with damaged pump units or parts.
- Only work on the motor when it is switched off. No work or checks require the motor to be running.
- Switch off the power supply to the motor before carrying out any work on it.
- Make sure that nobody can switch on the voltage unexpectedly while work is being carried out on the motor.
- Never work on electrical systems during a thunderstorm.
- Make sure immediately after ending the work that all protective and safety devices have been fitted again and are operational.
- Before switching on the motor, make sure that all electrical connections and safety devices have been checked and that all fuses and safeties have been set correctly.
- Make sure that no danger zones are freely accessible (e.g. rotating parts, suction locations, pressure output locations, electrical connections).
- Observe the pump manufacturer's commissioning instructions.
- If motors or pump units have been used in contaminated media they must be marked as such before handing them over to a third party (e.g. when submitting them for repair). Pay attention to possible residues in "dead spaces" (diaphragm cover).
- Contaminated motors or pump units must be marked as such before handing them over to a third party (e.g. when submitting them for repair).
- Repairs must only be carried out by authorized professional workshops. Use only original Franklin Electric spare parts.

3 Storage, Transport, Disposal

- Storage**
- ⇒ Store the motor in its original packaging until the time of installing it.
 - ⇒ If the motor is stored standing up, make sure that it cannot topple over (shaft always pointing up!).
 - ⇒ Do not store the motor in direct sunlight or within the reach of other heat sources.
 - ⇒ Observe the storage temperature (-15 - +60°C, see technical specifications).

Transport



DANGER

Falling loads may cause lethal injuries or may crush parts of the body!

- ⊗ Nobody is allowed to be located under suspended loads.
 - ⇒ Only use approved hoisting gear.
 - ⇒ Select the hoisting gear on the basis of the total weight to be transported.
-

Unpacking

- ⇒ After unpacking the motor check it for possible damage, e.g. damage to the diaphragm cover, housing, endbell, connection and motor cable.
- ⇒ Immediately inform the supplier of any damage found.



DANGER

Danger to life due to electrocution if the motor cable is damaged!

- ⊗ Do **not** install the motor and do **not** put it into operation.
-

Disposal In order to avoid environmental damage:

- Avoid contamination by lubricants, detergents etc.
- Dispose of the motor and the packaging material in a proper, environmentally sound manner.
- Observe local regulations.

4 Technical specifications

Description	Value
Performance/model number	6": 4 - 37 kW models 262 ... 8": 30 - 93 kW models 263 ... 10": 85 - 185 kW models 264 ... 12": 185 - 400 kW models 265 ...
Winding insulation	Standard: PVC Optional: PE2/PA (12 inch Standard)
Voltage range	220 V ... 1000 V, 3~ 50/60 Hz
Voltage tolerance (on the motor terminals)	50Hz: -10 to +6 % of U_N , i.e. at a nominal voltage of 380-415 V: 380 V -10 % = 342 V / 415 V + 6 % = 440 V 60Hz: ± 10% of U_N
Frequency tolerance	± 2%
Speed	approx. 2900 rpm at 50 Hz
Start alternatives	Direct starting, wye-delta-starting

Description	Value
Switching frequency	Max. number of switching actions per hour with a minimum off time of 90 seconds 6": 20 switching actions 8", 10": 10 switching actions 12": 5 switching actions
Protection	IP 68 according to IEC 60529
Submersion depth	max. 350 m
Installation location	Vertical (shaft up) to horizontal (only allowed if the pump size is identical to the motor size, e.g. 6" motor with 6" pump). The pump unit structure has to be able to withstand a sufficient axial motor load. 8"–93 kW and 10"–185 kW cannot be used horizontally. (For horizontal use up to 150 kW the Franklin Electric encapsulated motor is the technically better alternative.) No general guarantee when installed in pressure boosting systems
Operating temperature	≥ -3 °C
Sound pressure level	≤ 70 dB(A)
Maximum axial thrust towards the motor (8" and 10" motors: for clockwise rotation please consult Franklin Electric)	6": 4 - 26 kW 15.5 kN 30 - 37 kW 27.5 kN 8": all motors 45.0 kN 10": all motors 60.0 kN 12": all motors 60.0 kN (Optional 80 kN)
Maximum axial thrust away from the motor (only for a short-time load of max. 3 minutes; independent of performance rating)	6": 2.0 kN 8": 3.0 kN 10" / 12": 4.4 kN
Material	The person placing the order is responsible for selecting the correct material, specifically as regards its resistance in the medium to be transported. 304: Stator 304, powder-coated castings 316SS: Stator and castings 904L: Stator and castings
Motor fluid	FES 93 (approved, water-based emulsion) Filling fluid replacement on request
Weight	Technical data sheets (see appendix)
Storage temperature	-15 °C to +60 °C
Motor cable	KTW and VDE short motor cables are included in the delivery (Streamline motor cable only VDE tested). 6": Motor cable 4.0 m long 8", 10" & 12": Motor cable 6.0 m long
Connection flange	6", 8": NEMA flange (see appendix) 10" & 12": Standard flange (see appendix)
Temperature monitoring	PT100 temperature sensor for retrofitting (separate order; see appendix)

Motor cooling

Motor size (")	Performance rating (kW)	Coolant flow speed (m/s)	Max. medium temperature for winding (°C)	
			PVC	PE2/PA
6	5.5–15	0.2	30	50
	18.5–30	0.5	30	50
	37	0.5	–	45
8	30–52	0.2	30	50
	55–93	0.5	30	50
10	85–185	0.5	25	45
12	185 - 400	0,5	-	30

The **coolant flow speed** is the speed of the medium flowing along the motor casing during normal operation.

In the event of higher media temperatures, operation is only allowed if you

- use a special winding PE2/PA,
- reduce the performance (De-Rating, see Appendix),
- increase the coolant flow speed.

5 Pre-Operation Checks

5.1 Check the motor prior to installation

If a leak is visible or if the motor is more than one year old (e.g. in the event of re-use or after long storage):

⇒ Check the fluid level in the motor prior to installing it.

Tools You need the following tools for assembly and inspection work:

- Insulation measuring unit: 500 VDC testing
 - Filling Kit 308 726 103
- ⇒ Determine the age of the motor by checking the type plate (see Figure 5-1).

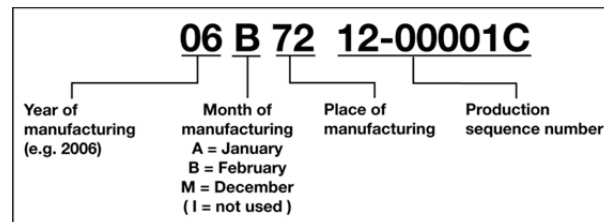

Figure 5-1: Type plate with date of manufacture

5.1.1 Checking the motor fluid



Motor damage due to being insufficiently filled!

- ⇒ Fill the motor with sufficient motor fluid
- ⇒ Wear safety goggles and gloves when filling and draining the motor.

⇒ Top up using original motor fluid from Franklin Electric FES93 (concentrate FES92 id. no. 308 353 941, 5-liter container) or clean drinking water.
Never use distilled water!

Filling volumes

- 6": approx. 5 litres
- 8": approx. 12 litres
- 10": approx. 20 litres
- 12": approx. 41 liters

Venting the motor

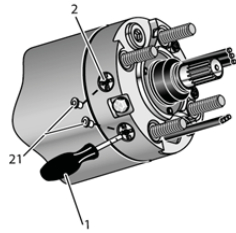

Figure 5-2: 6", 8", 10" motor

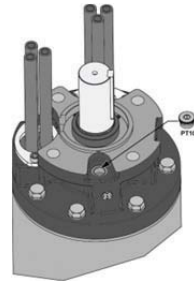
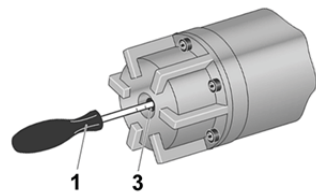

Figure 5-3: 12" motors

- ⇒ Place the motor horizontally so that the filling valve (2) is located at the highest position.
- ⇒ Remove the plug (21) from the filling valve (2).
- ⇒ Carefully push the test pin (1) into the filling valve (2) until air and some fluid escape from it.

Checking the motor 6-12"



6" / 8" / 10"

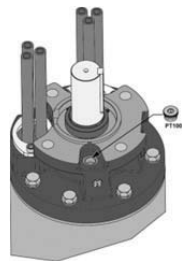

12"

Figure 5-5: Checking the motor fluid

- ⇒ Feed the test pin (1) through the opening in the diaphragm housing (3) (8"/10" de-central cover opening) until resistance is felt.
 - ⇒ Measure the actual diaphragm distance to the side of the opening in the diaphragm cover.
- If the measured result is not identical to the target value:
 44 mm ±2 mm (6"/8" motor)
 64 mm ±2 mm (10" motor) or
- ⇒ Top up or drain motor fluid.
 - ⇒ 12" – Place the motor vertically and remove the PT100 plug
 - ⇒ the fluid level must be on the threaded hole end

Topping up the motor 6-12"

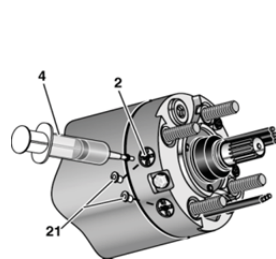

6" / 8" / 10"

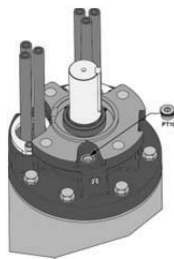

12"

Figure 5-6: Topping up the motor fluid

- ⇒ Apply the filling syringe (4) to the filling valve (2).
- ⇒ Top up the motor filling fluid until the value of the diaphragm position is lower than the target value.
- ⇒ 12" , overfill the motor with fluid
- ⇒ fit the PT100 plug screw

Adjusting the motor

- ⇒ Adjust the diaphragm position by draining (see Venting) or topping up motor fluid until the target value is reached. (6" / 8" / 10")
- ⇒ Fit the valve plug (21) again.



Risk of injury from pre-tensioned 8"/10" diaphragm cover during disassembly!

- ⇒ Secure the diaphragm cover: screw the M8 threaded rod through the central cover opening in the diaphragm insert cover.
- ⇒ Lock it from the outside using an M8 locknut.

5.2 Assembling the motor and pump



Note

These assembly and operating instructions only describe action steps related to the motor. You should also observe the pump unit manufacturer's instructions in all events.

Preparation

- Shaft protector removed
- Motor shaft rotated manually before assembly – runs freely after overcoming static friction
- Surfaces of parts to be connected are free from dust and dirt
- Coupling attached to the pump shaft, slides on the motor shaft

Assembly

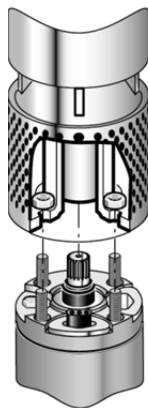

Figure 5-7: 6"

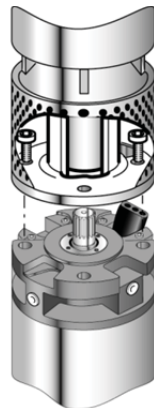

Figure 5-8: 8", 10", 12"

- ⇒ Apply water-resistant, acid-free grease (e.g. Mobil FM 102, Texaco, Cygnus 2661, Gleitmo 746) to the inner part of the coupling to the pump unit.
- ⇒ Make sure that the splined section (with 6" or 8" motors) is encased by an O-ring when the motor and the pump unit are assembled together.
- ⇒ Align the pump unit and motor shaft to each other and connect the pump unit and the motor.



Note

Only use fixing screws of the relevant grade and dimensions approved by the pump unit manufacturer. Observe the indicated torques.

- ⇒ Screw the motor to the pump unit, tighten the fixing screws crosswise as instructed.
6": M12 8": Bore Ø 17.5 mm 10" / 12": Bore Ø 22.0 mm
- ⇒ Protect the coupling location against contact.

5.3 Connecting the drop cable



Motor damage due to damaged motor cable!

- ⇒ Make sure that the motor cable is not in contact with any sharp edges.
- ⇒ Protect the cable against damage using the cable guard.

- The unit manufacturer's instructions regarding the cable connection have been observed
- Only extension cable and insulating material used which are suitable for the specific use (specifically drinking water) and which are approved for the temperatures occurring in the relevant medium
- Cable cross-sections: The tables in the appendix only serve as recommended suggestions. The fitter is responsible for the correct selection and dimensioning of the cable
- ⇒ Lay the cable along the pump.
- ⇒ Connect the ground conductor correctly (motors or integrated ground conductors are prepared for external grounding).
- ⇒ Protect the cable connection location against water penetration (shrink hoses, compounds or ready cable sets).
- ⇒ Make sure that the short motor cable is always fully surrounded by transport medium for proper cooling during operation.

5.4 Measuring the insulation resistance

This measurement is to be carried out using an insulation measuring unit (500 VDC, 1 min) before and while submersing the fully assembled unit at the place of use.

- ⇒ Before submersing the unit, connect a measuring cable to the ground conductor.
- ⇒ Make sure that the contact points are clean.
- ⇒ Connect the other measuring cable to every core of the connected motor cable in succession.

The insulation resistance is shown on the insulation measuring unit.

Minimum insulation resistance (ambient temperature 20°C) with extension cable:

- for a new motor > 4 MΩ
- for a used motor > 1 MΩ

For your information

Minimum insulation resistance (ambient temperature 20°C) without extension cable:

- for a new motor > 400 MΩ
- for a used motor > 20 MΩ

5.5 Powering the motor



Danger to life due to electrocution!

- ⇒ *Prior to making the electrical motor connection make sure that there is no more voltage on the entire plant and that nobody can accidentally switch on the voltage again while the work is being carried out.*

Observe the instructions on the motor type plate and dimension the electrical system accordingly. The connection examples in this chapter concern the actual motor and do not serve as recommendation for the upstream control elements.

- All action steps of the previous chapter have been carried out properly

Energy supply by generator



Note

We urgently recommend that you discuss the plant dimensions with the generator manufacturer.

The voltage tolerance, 50Hz: -10 % to +6 %/ 60Hz: ± 10%,(on the motor terminals) and the deviation of a motor current from the mean value of all three currents must not be more than 5 %.

- Generator selected on the basis of the motor start behaviour, i.e. starting current with a mean $\cos \varphi$ of 0.5
- Sufficient continuous generator power available

- ☑ Starting voltage at least 55 % of the nominal voltage
- ⇒ You must follow the following switch-on sequences unconditionally:
first switch on the generator and then the motor.
first switch off the motor and then the generator.

Fusing and motor protection

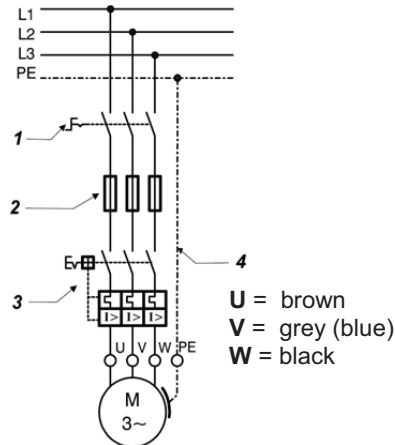

- ⇒ Provide an external mains switch (1) enabling the voltage to be removed from the system.
- ⇒ Provide fuses (2) for every single phase on site.
- ⇒ Provide a motor starting and protection switch (3) (see connection alternatives)
- ⇒ Provide an emergency stop system, if required for your specific application.
- ⇒ Ground the motor (4) (exterior grounding possible with all motors)

Figure 5-10: Fusing and motor protection

Surge voltage protection

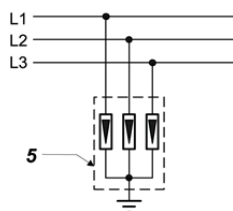

- ⇒ Integrate an overload protector in accordance with IEC 60099 in the power supply (lightning safety (5)).

Figure 5-12: Surge voltage protection

Connection alternatives

The connection example shows the usual circuit with a right-hand field and an anti-clockwise direction of rotation:

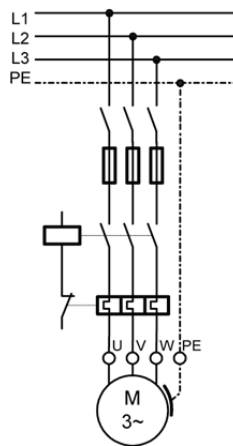

Figure 5-13: Direct starting

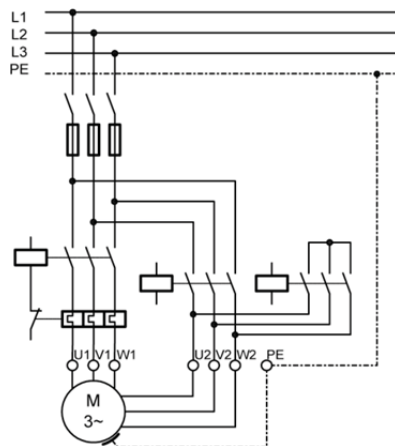

Figure 5-14: Wye-delta-starting

Motor safety switch

A motor safety switch (overload relay) is absolutely necessary!

Only use thermal trips of tripping categories 10A or 10, with

- ⇒ tripping time < 10 s at 500 % I_N (nominal current),
- ⇒ phase sensitivity,
- ⇒ Temperature compensation.

- ⇒ Set the motor protection unit to the value of the operating current measured without exceeding the rated motor current I_N (as indicated on the type plate); recommendation: 90 % of the nominal motor current.

6 Motor Operation

6.1 Proper motor cooling



Damage to the motor and the motor cable due to overheating

- ⇒ Make sure that the coolant flow speed along the motor is sufficient.
 - ⇒ Make sure that the short motor cable is always fully surrounded by transport medium for proper cooling.
-

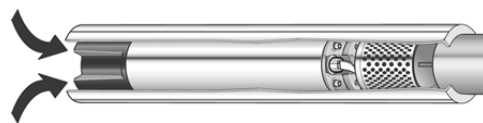

Figure 6-1: Cooling tube

If the required minimum coolant flow speed cannot be reached (e.g. if the inlet opening of the well is located above the motor or if using large-diameter wells):

- ⇒ Fit a cooling tube (see figure 6-1).
- ⇒ Make sure that the cooling tube encases the entire motor and the pump water inlet opening.
The motor is force-cooled.

6.2 Providing a check valve and level sensor

- ⇒ Provide one spring-loaded check valve in the production tube in case no such check valve has been fitted in the pump.
- ⇒ Ensure that the check valve is no further than 7 meters away from the pump.
- ⇒ Install a level sensor for wells with a highly varying water inflow.

6.3 Switching on the motor

- All action steps of the previous chapter have been carried out properly
- ⇒ Switch on the motor using the mains switch in the control cabinet.
- ⇒ Measure the following values after switching on:
 - Motor operating current in every phase
 - Mains voltage when motor is running
 - Level of the medium to be transported
- ⇒ **Immediately switch off the motor if:**
 - the nominal current as specified on the type plate is exceeded,
 - voltage tolerances of more than, 50Hz: -10 % to +6 %/ 60Hz: ± 10%, relative to the nominal voltage are measured on the motor,
 - there is a risk of the motor running dry,
 - motor current deviates from the mean value of all three currents by more than 5 %.

6.4 Motor operation with frequency converter



Note

When operating a motor with a frequency converter, the relevant operating manual must be observed!

- ⇒ Make sure that the motor current in all operating levels of the regulating range does not exceed the nominal motor current indicated on the type plate.
- ⇒ Adjust the frequency converter so that the limit values for the nominal motor frequency of min. 30 Hz and max. the value of the nominal motor frequency (50 or 60 Hz) are observed.
- ⇒ Limit any voltage peaks on the motor when using a frequency converter to the following values: max. voltage rise 500 V/μs, max. voltage peak 1000 V.
- ⇒ Make sure that the running up time from 0 to 30 Hz and the deceleration time from 30 to 0 Hz is maximum one second.
- ⇒ Dimension the cable such that power loss due to additional filters is taken into consideration.
- ⇒ Make sure that the required coolant flow speed along the motor is also observed with frequency converter operation.

6.5 Motor operation with soft starter



Note

When operating a motor with a soft starter, the relevant operating manual must be observed!

- ⇒ Set the starting voltage of the soft starter to 55 % of the nominal voltage and set the running up and delay times to max. three seconds.
- ⇒ Bridge the soft starter after running up, using a contactor.

7 Maintenance and service

The motor is maintenance-free, no maintenance or service activities are necessary.

8 Troubleshooting

Fault	Remedy
Unusual noises, problems with the proper running of the pump or the pump switching on and off too frequently.	⇒ Try to find the cause of the fault on the pump unit.
The pump repeatedly switches off	<ul style="list-style-type: none"> ⇒ Have the insulation resistance checked by a professional (see chapter 5.4). ⇒ If no cause can be found in the motor or the motor cable: Have the electrical system checked.

9 Service

Repairs must only be carried out by authorised professional workshops (only use original Franklin Electric spare parts).

If you have any questions or problems, please contact your dealer or contact Franklin Electric via Internet (www.franklin-electric.eu) or via mail to: field-service@franklin-electric.de.

10 Appendix

Page	Explanation
Page A	Outline drawing 6" and 8"
Page B	Outline drawing 10" and 12"
Page C	Assembly instructions PT100
Page D	Cable cross-sections DOL and YD

6" Rewindable

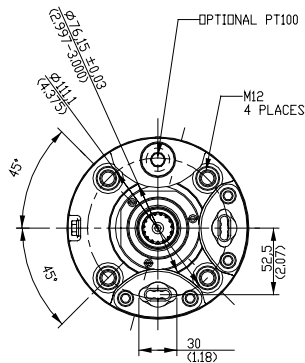
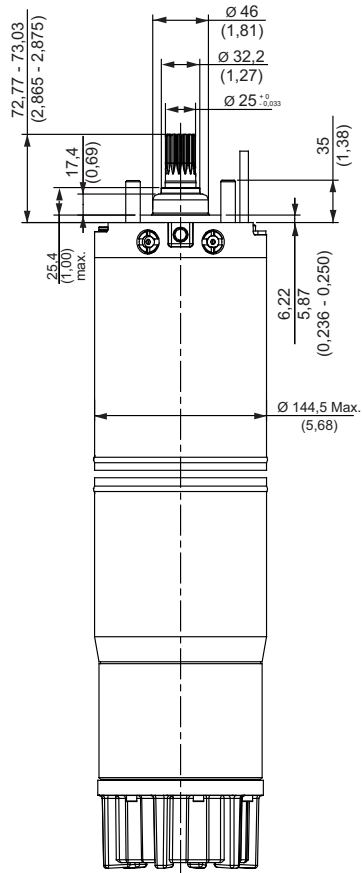

8" Rewindable

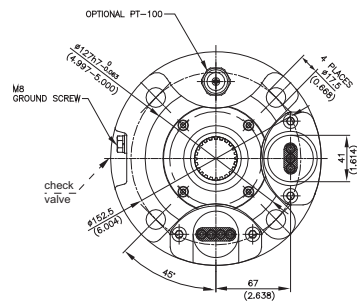
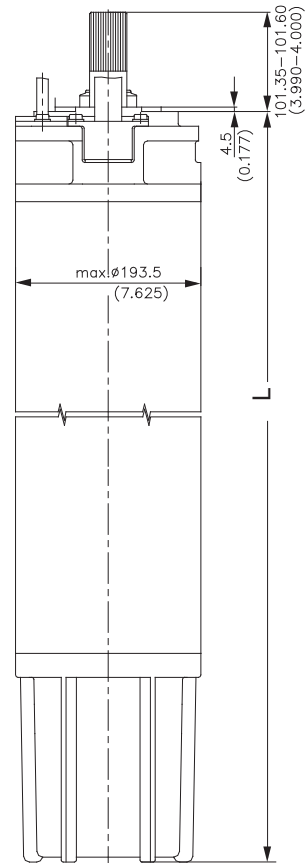

P_N [kW]	304* L [mm]	316** L [mm]	Motor Weight [kg]
4	699	712	48
5,5	699	712	48
7,5	719	732	50
9,3	749	762	53
11	779	792	56
13	829	842	61
15	874	887	66
18,5	919	932	70
22	1009	1022	79
26	1114	1127	90
30	1214	1227	100
37	1294	1307	107

P_N [kW]	304/316 L [mm]	Shipping Weight [kg]
30	1140	140
37	1140	140
45	1230	156
52	1340	179
55	1340	179
60	1470	198
67	1470	198
75	1560	215
83	1560	247
93	1740	247

10" Rewindable

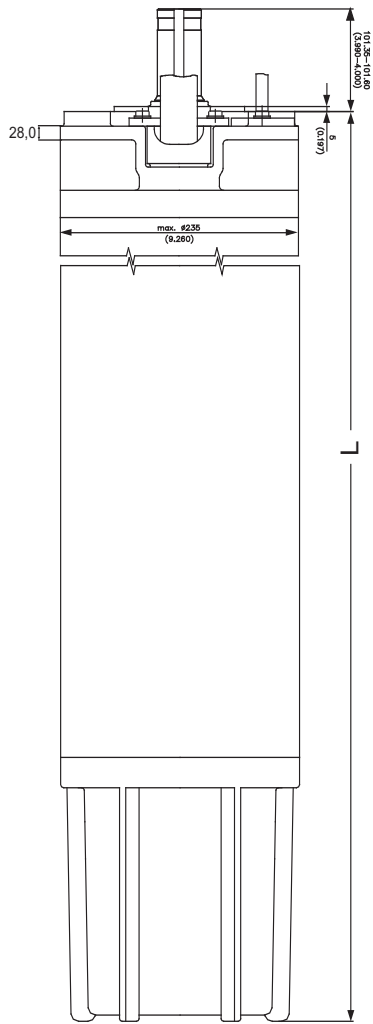

12" Rewindable

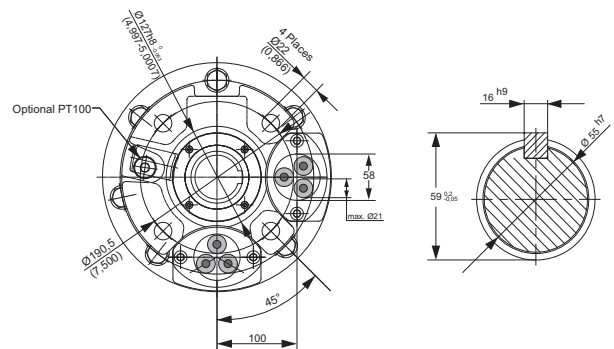
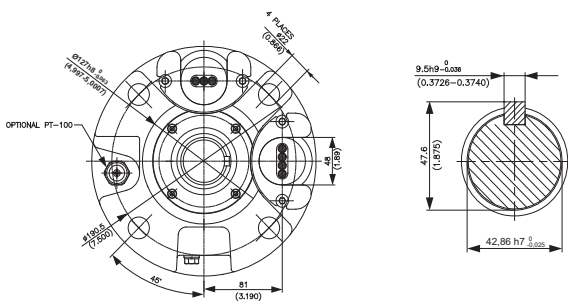
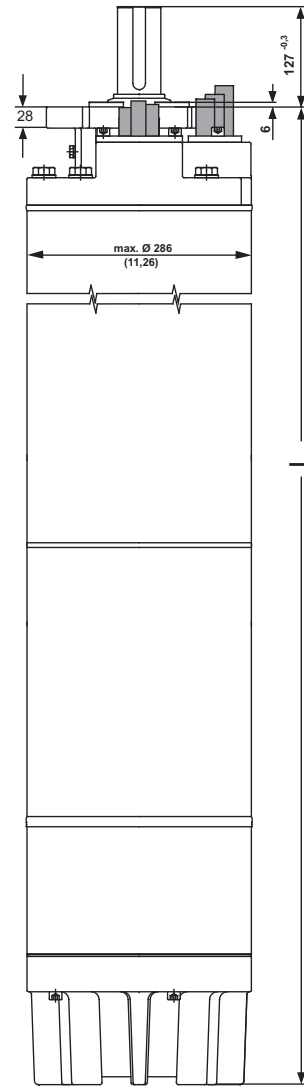

P_N [kW]	L [mm]	Motor Weight [kg]
85	1419	280
110	1529	315
130	1659	362
150	1769	413
185	1919	449

P_N [kW]	L [mm]	Motor Weight [kg]
185	1703	595
220	1893	663
250	1893	663
300	2043	726
350	2143	769
400	2193	794

Installation - Instruction " PT 100 "

Required parts and tools

- PT 100 Kit: (308 016 40..)
- Filling – Kit: (308 726 103)
- Filling liquid (5L FES92): 308 353 941



Caution

- Wear safety goggles and gloves when filling and draining the motor
- Do not pull on the PT 100

Pressure compensation (Fig.1)

Stand the motor vertically and remove the plug (21) from the filling valve (2). Remove the plunger from the syringe and carefully push the syringe (4) into the fill valve (2) until motor fluid escapes into the cylinder; collect the motor fluid in a clean tank. When the interior is no longer pressurized, that is no fluid flows out, remove the syringe from the valve and reassemble it.

(Fig.1)

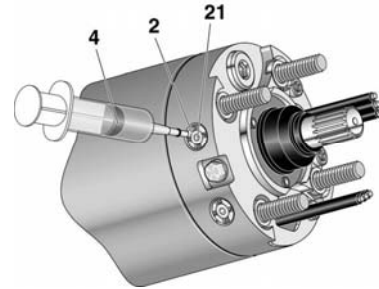

PT100 assembly (Fig.2)

Remove the plug (22) from the end bell. Put the jam nut (12), washer (13) and seal (14) on the PT 100 (11) so that the end of the PT 100 sleeve is even with the jam nut face surface (12). Tighten the jam nut (approx. 15 Nm) and keep the above described position.

(Fig.2)

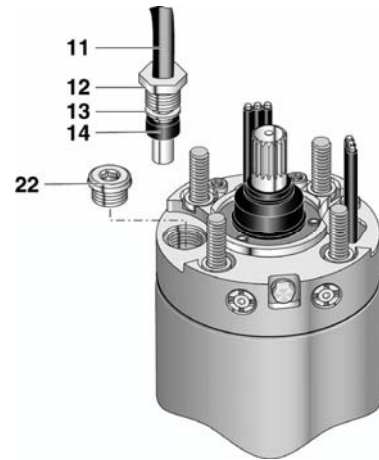

Topping up

Filling (Fig. 1): Apply the syringe (4) to the fill valve (2). Top up the motor fluid until the value of the diaphragm position is lower than the target value:

- 44 mm +/- 2 mm (6"/8" motor)
- 59 mm +/- 2 mm (6" Streamline motor)
- 64 mm +/- 2 mm (10" motor)
- (12" motor - overfill the motor with fluid)

Venting (Fig. 3): Place the motor horizontally so that the filling valve (2) is located at the highest position. Carefully push the test pin (1) into the filling valve (2) until air and some fluid escapes.

(Fig.3)

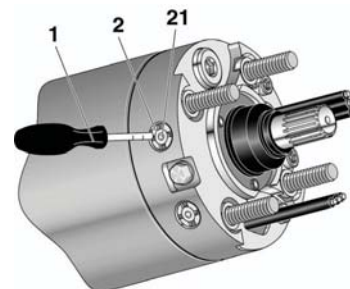

Checking (Fig. 4): Feed the test pin (1) through the opening in the diaphragm cover (3) (8"/10" de-central cover opening) until resistance is felt. Measure the actual diaphragm distance to the side of the opening in the diaphragm cover. Adjust the diaphragm position by draining (see venting) or topping up motor fluid (tap water) until the target value is reached. Fit the plug (21) again.

(Fig.4)

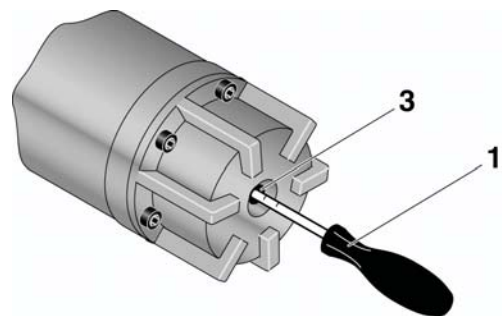

Electric installation:

Adjusting switching equipment		
PVC	Winding insulation	55°C
PE2/PA	Winding insulation	75°C

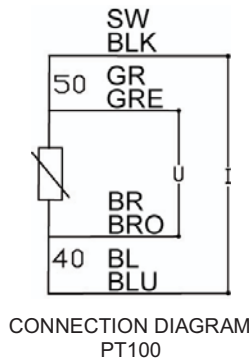



maximum lengths in meters for 400V / 50Hz and 5% voltage drop at 30°C ambient
 Jacketed Cable Ampacity, IEC Publication 364-5-523 (1983 edition), Table 52-B1, Installation Methods C & G

DOL start

rating		cable size mm ² , copper wire - 70°C rated insulation															
KW	HP	2,5	4	6	10	16	25	35	50	70	95	120	150	185	240	300	400
4	5,5	180	290	430	710												
5,5	7,5	130	210	320	530	830											
7,5	10	90	150	230	390	610	940										
9,3	12,5	80	130	190	320	510	770										
11	15	60	100	160	270	430	650	890									
13	17,5		90	140	230	370	560	770									
15	20		80	120	200	320	490	680	920								
18,5	25			100	160	260	400	540	740	980							
22	30				140	220	340	470	630	840							
26	35				120	190	290	390	540	720	920						
30	40					160	250	340	470	620	790	940					
37	50					130*	200	280	380	500	640	760	890	1020			
45	60						170	240	330	440	570	690	810	940			
52	70						150*	210	290	390	500	600	710	820	980		
55	75						140*	190	270	360	470	560	660	770	910		
60	80							180	250	340	440	530	630	730	870	1010	
67	90							160*	220	300	390	460	550	630	750	860	1000
75	100								200*	270	350	420	490	570	680	780	910
83	111								180*	250	320	390	450	530	630	730	850
85	114									230	290	350	410	480	570	650	750
93	125									220*	280	340	390	460	550	620	720
110	150										220	270	310	360	420	480	550
130	175										200*	240	280	330	390	440	520
150	200											200*	240	280	330	380	440
185	250													210*	250	280	330

Wye - Delta

rating		cable size mm ² , copper wire - 70°C rated insulation															
KW	HP	2,5	4	6	10	16	25	35	50	70	95	120	150	185	240	300	400
4	5,5	270	430	640													
5,5	7,5	190	310	480	790												
7,5	10	130	220	340	580	910											
9,3	12,5	120	190	280	480	760											
11	15	90	150	240	400	640	970										
13	17,5	70	130	210	340	550	840										
15	20	70	120	180	300	480	730	1020									
18,5	25	60	90	150	240	390	600	810									
22	30		70	120	210	330	510	700	940								
26	35		60*	100	180	280	430	580	810								
30	40			90	150	240	370	510	700	930							
37	50				120	190	300	420	570	750	960						
45	60				100	160	250	360	490	660	850						
52	70				90*	150	220	310	430	580	750	900					
55	75					130	210	280	400	540	700	840	990				
60	80					120	190	270	370	510	660	790	940				
67	90					100	180	240	330	450	580	690	820	940			
75	100					90*	150	210	300	400	520	630	730	850	1020		
83	111						130	190	270	370	480	580	670	790	940		
85	114						130*	180	250	340	430	520	610	720	850	970	
93	125						120*	160	240	330	420	510	580	690	820	930	
110	150							130*	190	250	330	400	460	540	630	720	820
130	175								160*	220	300	360	420	490	580	660	780
150	200								150*	190	250	300	360	420	490	570	660
185	250									190*	240	270	310	370	420	490	

D  **Franklin Electric**

EC Herstellererklärung

Hersteller: Franklin Electric Europa GmbH
Rudolf-Diesel-Strasse 20
D-54516 Wittlich

Produkt: Wiederablebare Unterwassermotoren

Typbezeichnung: 262... 263... 264... 265... 266...

Die oben genannten Produkte sind mit den folgenden Europäischen Richtlinien konform:

2006/95/EC (Niederspannungsrichtlinie),
und
2004/108/EC (EMC Richtlinie)

Angewendete harmonisierte Standards: **EN 60034-1**

P. Klippel
Engineering & Quality Manager
15 December 2009

54516 Wittlich Germany, Rudolf Diesel Str 20

F  **Franklin Electric**

Déclaration de Conformité CE

Fabricant: Franklin Electric Europa GmbH
Rudolf-Diesel-Strasse 20
D-54516 Wittlich

Produit: Moteur immergés rebobinables

Désignation: 262... 263... 264... 265... 266...

Les produits mentionnés ci-dessus sont conformes avec les Directives Européennes suivantes :

2006/95/EC (directive Basse Tension)
et
2004/108/EC (Directive EMC)

Standards harmonisés appliqués : **EN 60034-1**

P. Klippel
Engineering & Quality Manager
15 December 2009

54516 Wittlich Germany, Rudolf Diesel Str 20

I  **Franklin Electric**

EC Dichiarazione di Conformità

Produttore: Franklin Electric Europa GmbH
Rudolf-Diesel-Strasse 20
D-54516 Wittlich/Germany

Prodotto: Motori sommersi riavvolgibili

Motori del tipo: 262... 263... 264... 265... 266...

I prodotti sopra descritti sono conformi alle seguenti Direttive Europee

2006/95/EC (Direttiva Basso Voltaggio)
(H)
2004/108/EC (Direttiva EMC)

In conformità' allo standard **EN 60034-1**

P. Klippel
Engineering & Quality Manager
15 December 2009

54516 Wittlich Germany, Rudolf Diesel Str 20

E  **Franklin Electric**

Declaración de Conformidad CE

Fabricante: Franklin Electric Europa GmbH
Rudolf-Diesel-Strasse 20
D-54516 Wittlich/Germany

Producto: Motores Sumergibles rebobinables

Modelos: 262... 263... 264... 265... 266...

Los productos mencionados anteriormente están en conformidad con las siguientes Directivas Europeas

2006/95/EC (Directiva Baja Tensión),
y
2004/108/EC (Directiva EMC)

Normas armonizadas aplicadas: **EN 60034-1**

P. Klippel
Engineering & Quality Manager
15 December 2009

54516 Wittlich Germany, Rudolf Diesel Str 20

P  **Franklin Electric**

Declaração de Conformidade EC

Produtor: Franklin Electric Europa GmbH
Rudolf-Diesel-Strasse 20
D-54516 Wittlich/Germany

Produto: Motores Submersíveis do tipo rebobinável

Designação do tipo: 262... 263... 264... 265... 266...

Os produtos acima estão em conformidade com as seguintes diretivas europeias em vigor:

2006/95/EC (Directiva de baixa tensão),
e
2004/108/EC (Directiva EMC)

Padrões harmonizados aplicáveis: **EN 60034-1**

P. Klippel
Engineering & Quality Manager
15 December 2009

54516 Wittlich Germany, Rudolf Diesel Str 20

GR  **Franklin Electric**

EC Δήλωση Συμμόρφωσης

Κατασκευαστής: Franklin Electric Europa GmbH
Rudolf-Diesel-Strasse 20
D-54516 Wittlich/Germany

Προϊόν: Rewindable Submersible motors

Όνομασία Τύπου: 262... 263... 264... 265... 266...

Τα παραπάνω προϊόντα είναι σύμφωνα με τις ακόλουθες ευρωπαϊκές οδηγίες:

2006/95/EC (Οδηγίες για χαμηλή τάση)
και
2004/108/EC (EMC Οδηγίες)

Εφαρμοζόμενα εναρμονισμένα πρότυπα : **EN 60034-1**

P. Klippel
Engineering & Quality Manager
15 Δεκεμβρίου 2009

AR  **Franklin Electric**

بيان الشركة المتصلة طبقاً لتعليمات المفوضية الأوروبية

المنتج: شركة فرانكلين الكهربائية الأوروبية المحدودة
(Rudolf-Diesel-Strasse 20, Wittlich 54516 ألمانيا)

النموذج: محركات غاطس قابلة لإعادة التوليد

أسماء النماذج: 262... 263... 264... 265... 266...

توافق المنتجات المذكورة أعلاه مع التعليمات الأوروبية التالية

2006/95/EC (التعليمات الخاصة بتسليم المنتجات)
و
2004/108/EC (التعليمات الخاصة بالتوافق الكهرومغناطيسي)

EN 60034-1 المعايير المتناسقة لتجهيز الآلات الأخرى.

المهندس
مدير ضمان الجودة والموثوقية
15 كانون الأول / ديسمبر 2009

54516 Wittlich Germany, Rudolf Diesel Strasse 20

TR  **Franklin Electric**

Üretici Beyannameisi

Üretici: Franklin Electric Europa GmbH
Rudolf-Diesel-Strasse 20
D-54516 Wittlich

Ürünler: Tekrar Sarımlı Dalgıç Motorları

Modeler: 262... 263... 264... 265... 266...

Adı verilen ürünlerimiz, aşağıda belirtilen Avrupa Birliği yönetmelikleri ile uyumludur:

2006/95/EC: Alçak Gerilim Cihazları Yönetmeliği
2004/108/EC: EMC Elektromanyetik Uyumluluk Yönetmeliği

EN 60034-1: Diğer Elektrik Makinaları Bölümü 1, Beyan değerleri ve performans standartları

P. Klippel
Mühendislik & Kalite Müdürü
Aralık 15, 2009

Buffalo, Indiana 46714, USA, 380-624-2600

RU  **Franklin Electric**

Заявление о соответствии стандартам EC

И изготовитель: Franklin Electric Europa GmbH
Rudolf-Diesel-Strasse 20
D-54516 Wittlich/Germany

Название изделия: Перемотываемые Погружные Электродвигатели

Типы изделий: 262... 263... 264... 265... 266...

Вышеуказанные погружные электродвигатели соответствуют требованиям следующих Европейских Директив:

2006/95/EC: Директива Европейского парламента и Совета от 12 декабря 2006 года по унификации правовых норм государства-члена ЕС относительно применения электрического оборудования в пределах определенного диапазона значений напряжения (кодифицированная редакция)

2004/108/EC: Директива Европейского парламента и Совета по унификации законодательных директив стран-членов ЕС по электромагнитной совместимости (директива по EMC)

Применены сопоставленные стандарты: **EN 60034-1**



П. Клиппель
Менеджер по Качеству и Технологии
15 декабря 2009 года

Улица Рудольфа Диеля 20, 54516 Виттих / Германия

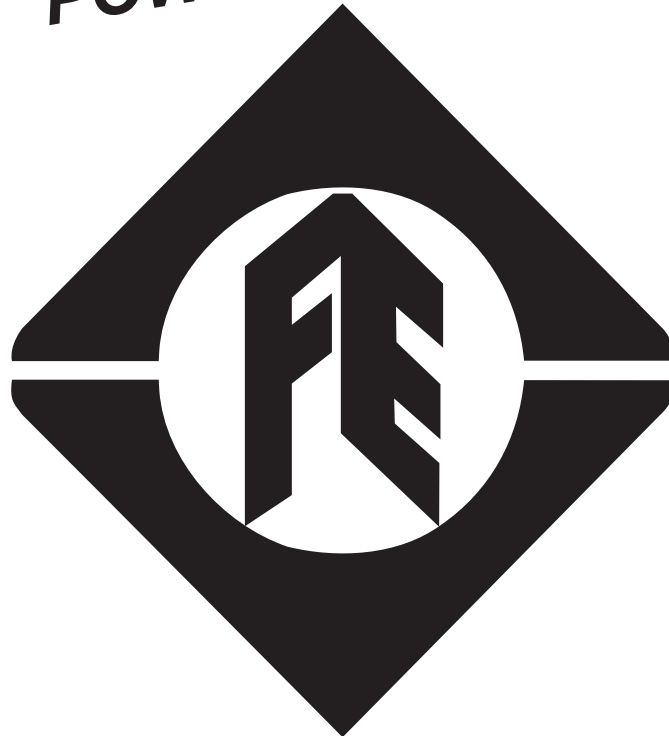

Franklin Electric

POWERED BY



Franklin Electric

QUALITY IN THE WELL