

SubMonitor

Installation & Operation Manual



Franklin Electric

DECLARATION OF CONFORMITY

Application Of Council Directive(s) 89/336/EEC Electromagnetic Compatibility
73/23/EEC Low Voltage

Manufacturer's Name \ Address: Franklin Electric Co., Inc.
100 Schaefer Dr.
Gas City, IN 46933

European Representative Name: Dieter Schuch

European Representative Address: Franklin Electric Europa GmbH
Gutenberg Strasse 8
D-54516 Wittlich
Germany

Model Name: SubMonitor

Conformance to Directive(s) Product Standard: EU Directive **89/336/EEC** using:
EN 55011:1998, A1:1999 & A2:2002
emissions (See Note 1)

EU Directive **73/23/EEC** using:
EN 61010-1:2001

Equipment Type/Environment: Equipment for Measurement, Control &
Laboratory use Light \ Heavy industrial

Note(s)

(1) Product meets emission limit/methods of EN 55011 Class B.
Product meets the immunity levels/methods of EN 61326

Year of Manufacture: 2005

We, the undersigned, hereby declare that the equipment specified above conforms to the above Directive(s).

Manufacturer
Franklin Electric Co., Inc.

Legal Representative in Europe
Franklin Electric Europa GmbH

Full Name
Quinn Wise

Full Name
Dieter Schuch

Position
Sr. Project Engineer

Position
Product Manager

Place
Bluffton , IN, USA

Place
Wittlich Germany

Date March 28, 2005

Date March 28, 2005



Franklin Electric

400 E. Spring Street
Bluffton, IN 46714
Tel: 260-824-2900
Fax: 260-824-2909
www.franklin-electric.com

Contents

To Set SubMonitor Language.....	2
SubMonitor Submersible Pump Motor Protection System.....	3
Components	4
Installation.....	5-6
Quick Guide to Setup	7
Additional Programmable Options	8
Password.....	9
Event History.....	10
Key Parameters in Event History	11
Other Features.....	12
Special Conditions	12
Programmable Options.....	13
Troubleshooting.....	14
Maintenance	15
Specifications	16
Mounting Dimensions	17
Notes	18

SubMonitor

To Set SubMonitor Language:

After data sync, from monitoring screen,

Select→Menu, press button

Select→5 Detailed Setup, press button

Select→K Change Password, press button

Select→English, press button

Turn knob until the desired language is displayed, press button to set

Select→OK to exit

SubMonitor Submersible Pump Motor Protection System

Franklin's SubMonitor is an easy to use, programmable protection device for Franklin Electric three-phase submersible motors.

SubMonitor's features provide advanced protection of submersible motors:

- SubMonitor operates over the full range of three-phase motor voltages, 200 - 575 volts, 50 and 60 Hz.
- Operates on motors with service factor current rating of 5 amps through 350 amps - no external current transformers required.
- Protects motors and pumps from overloads, underloads, overvoltage, undervoltage, unbalanced currents, phase loss*, chattering contacts, and phase reversal.
- Operates with a Subtrol-equipped submersible motor to provide motor overheat protection.
- Monitors and displays three-phase voltages, three-phase currents, and pump status.
- When a fault occurs, displays the fault conditions and status.
- Records and displays the history of up to 502 fault trip events, plus records changes to programmable parameters.
- Records total pump operating time.
- Features a detachable display unit which may be mounted on the front of a panel for viewing operating status.
- Includes the option of password protection to avoid tampering.
- Easy mounting with DIN rail mounts.
- Totally integrated unit - current transformers are built in.

Simple Programming

SubMonitor has been pre-programmed with default settings for submersible motors and pumps. Set-up is as simple as setting the motor ratings - voltage, Hertz, and SF max amps.

Additional programming options can be selected if desired to customize the features and levels of protection. See page 7 for an overview of the menu structure and page 12 for a full list of programmable options.

All programming set-up can be made prior to installing at the field site by connecting 230 volts single-phase between voltage inputs L1, L2 and L3 of SubMonitor (jumper between L2 and L3) and entering the motor data and any other options.

* Phase loss is a severe case of current unbalance. Reported unbalance trips are due to phase loss when current on one of the legs (noted in the data log) is very small, or when the current unbalance function has been disabled.

SubMonitor

Components

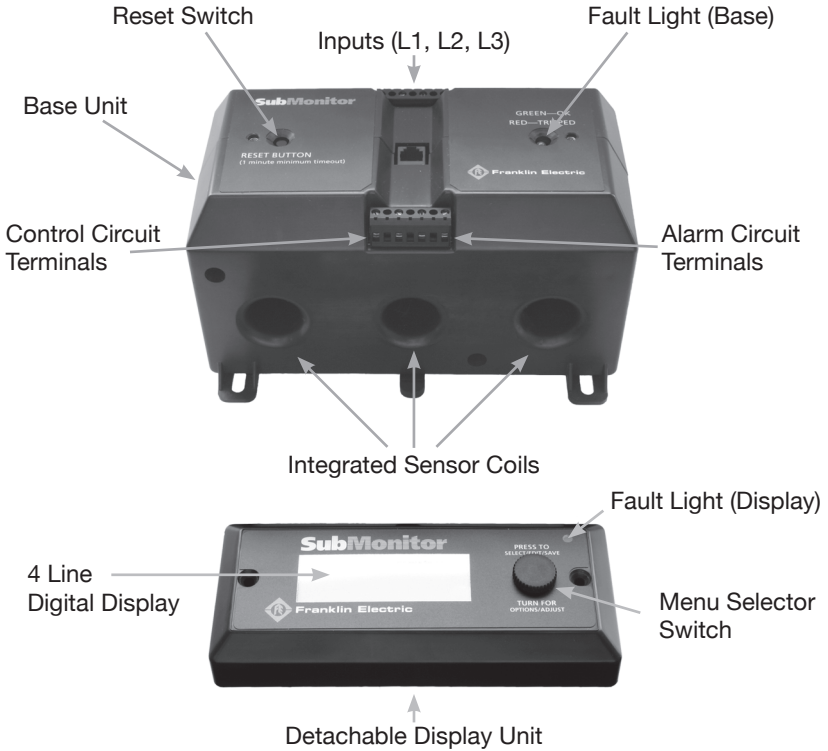

Plug-in Wiring Connectors

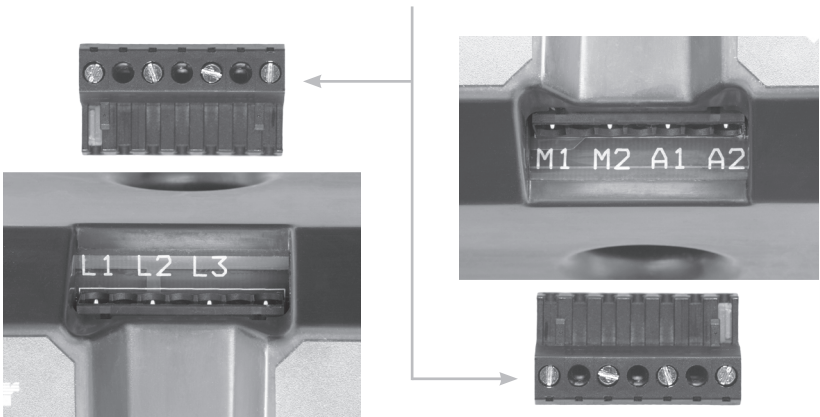

Installation



WARNING: Hazardous Voltage.

Electrical shock can cause death or serious personal injury.

This equipment should be installed by technically qualified personnel. Failure to install in compliance with national and local electrical codes and within Franklin Electric recommendations may result in electrical shock or fire hazard, unsatisfactory performance, or equipment failure.

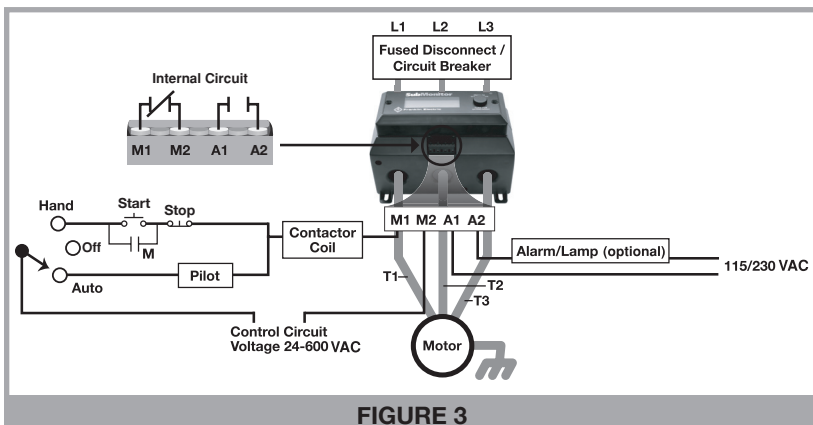
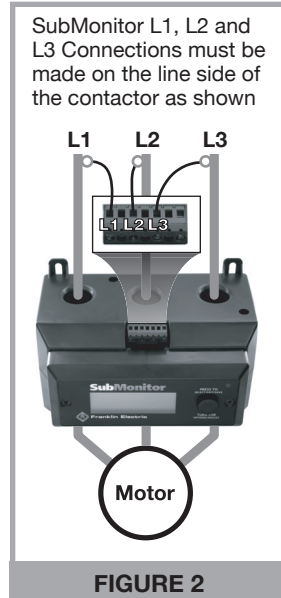
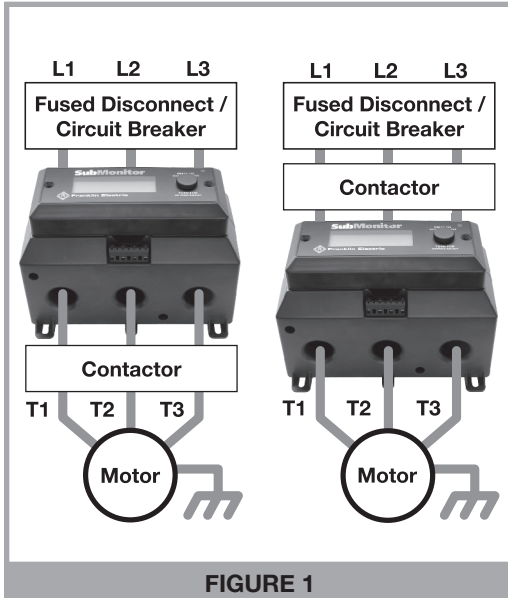

SubMonitor

SubMonitor Wiring

1. Read this section of the manual thoroughly.
2. Disconnect power & verify that power is off before installing SubMonitor.
3. Install SubMonitor as illustrated in the wiring diagram in Figure 1. SubMonitor may be mounted above or below the contactor as shown. To use the DIN rail mount, first attach the DIN rail clip to the bottom of the base unit. Then secure the SubMonitor to the DIN rail. Attach the top rail first, then apply downward pressure until the bottom rail snaps into place.
4. Connect three phase power leads to the plug-in connector L1, L2, and L3 terminals as shown in Figure 2. Wire strip length is 5/16" (8mm). **The L1, L2, L3 connections must be made to the line side of the contactor passing through the sensor coils as shown in Figure 2.** (This is because the overheat signal from the motor must first pass through the sensor coils, then into the L1, L2, and L3 terminals of SubMonitor).
5. Connect the control circuit wires to the M1 and M2 plug-in connector terminals, and signal circuit wires to the A1 and A2 plug-in connector terminals (Figure 3). Tighten all terminals to 4.5 in-lbs and install the plug-in connectors into SubMonitor (plugs are keyed to avoid misconnection).
6. Pass the T1, T2, and T3 motor power leads through the sensor coils in the base unit.
7. **NOTE:** 6-lead Wye-Delta motors - for a 6-lead motor with a Wye-Delta control panel, each sensor coil must encircle a pair of leads which connect to the same line in the delta connection, such as T1-T6; T2-T4 or T3-T5.
8. As an option, the SubMonitor display unit is detachable and can be mounted on the exterior of the panel door (requires a small punch-out and two screw holes). Use the extension cable provided in the kit to connect the base unit to the display unit.

Lightning Arrester

1. Install the lightning arrester and connect line leads to the line side of the contactor as shown in Figure 4.
2. The lightning arrester ground lead must be connected to water strata ground to provide suitable surge protection. Connect metal-to-metal to well casing, drop pipe, or to the submersible motor with wire the same size as drop cable wires.

NOTE: Refer to Franklin Electric Submersible Motor Application, Installation and Maintenance (AIM) manual for further discussion of lightning protection.

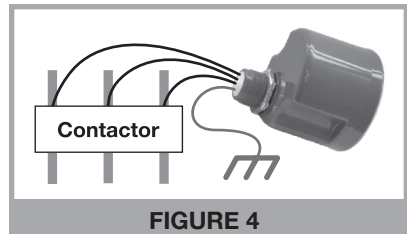

FIGURE 4

Quick Guide to Setup

Points 1 through 3 below describe navigation: how to get around among the two menus and several screens. Point 4 describes how to change a parameter.

1. On initial power-up, ***the control circuit will be locked out until the motor voltage and SF Amps are set.*** After a 30 second delay while data sync is completed, the monitor screen will report SF Amps Set Too High: Locked Out*. Notice →MENU in the lower right corner—the arrow indicates that pressing the knob will take you to the menu Basic Setup.
2. From Basic Setup, rotate to Select Motor and press, and you will arrive at the Select Motor screen where you can set motor Hz, volts, and SF Amps (read point 4 below). Set the SF Amps to match the motor SF Max Amps by adjusting each digit individually. When you are done with this screen, rotate to →OK and press, thereby going back to Basic Setup.
3. Note that selecting Detailed Setup takes you to a longer menu with items that are lettered. Select Back: Basic Setup to return to Basic Setup. Refer to charts on page 7 and page 12 for structure and available options of menus.
4. When you are on a selected screen of either Basic Setup or Detailed Setup and you want to change a setting:
 - a. Rotate the knob until the arrow points to the item to be changed.
 - b. Press the knob and the arrow will blink. Turning the knob now changes the value of the item.
 - c. When the item is correctly adjusted, press the knob and the arrow stops blinking.
 - d. You can now rotate the knob to another item on the screen. Selecting →OK returns you to the parent menu.

SubMonitor is now set up to protect your motor and pump, and will allow the motor to start when you return to the Monitor screen and select Manual Reset. After any Manual Reset, there is a one minute off-time delay before the motor starts.

Note that the signal circuit and red Fault LED are ON until the motor data is entered and Manual Reset is pressed.

* **Phase Reversal**—SubMonitor has a built in phase sequence meter. If initial power up displays Phase Reversal, the incoming voltage at SubMonitor's L1,L2, L3 terminals is negative sequence, and the contactor is locked out until the phase sequence is corrected.

Figure 2 on page 4 shows SubMonitor inputs L1, L2, and L3 connected to motor leads T1, T2, and T3 respectively. While this order is not critical for operation of SubMonitor, it should provide proper motor rotation with positive sequence line voltage.

SubMonitor

Additional Programmable Options

The table on page 12 shows the parameters that may be changed in the Basic Menu and Detailed Menu screens, including the default settings.

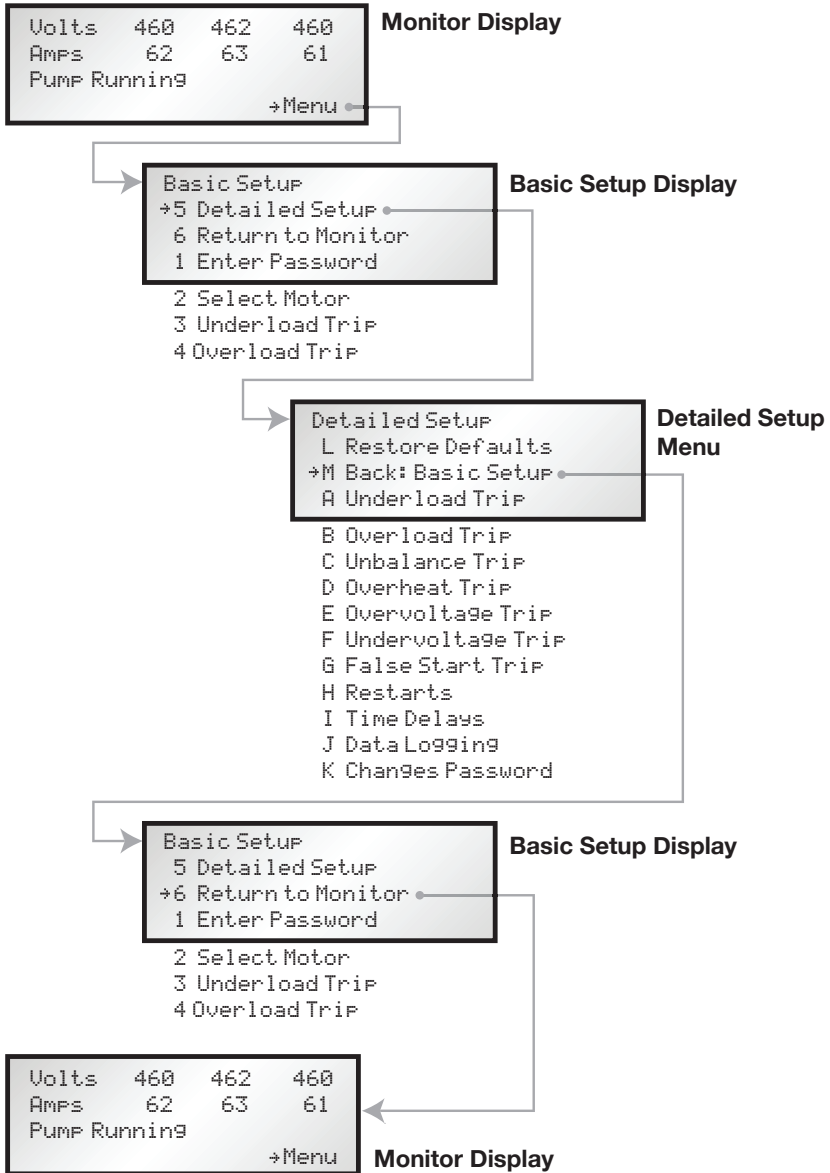

Password

1. The password is factory preset to 0 0 0, which **disables** the password protection. With the password protection disabled, all functions in the menus can be changed by any user.
2. If the password protection is **enabled**, **all** parameters in the menus can be viewed but not changed until the correct password is entered.
3. Using the password function:
 - a. Go into the `Detailed Setup` menu and select `Change Password`. Enter the three digits of the password sequentially left to right, just like a combination lock. Select `>OK` to return to the `Detailed Setup` menu.
 - b. Go to the `Basic Setup` menu and select `Enter Password`. Enter the password sequentially left to right.
4. If you forget your password, refer to the `Enter Password` screen which shows a password code. You may call the FE Hotline at 1-800-348-2420 to convert the code into your three digit password.
5. The password resides in the Base Unit. If you change display units, you will need to know the password that was used with the base unit.
6. If you wish to disable the password protection:
 - a. Go to `Enter Password` in the `Basic Setup` menu. Enter the correct password.
 - b. Go to `Change Password` in the `Detailed Setup` menu. Enter the password 0 0 0 sequentially left to right.
7. When a correct password has been entered, changes can be made for the next 20 minutes. To get another 20 minutes, re-enter the password.
8. The 20 minute valid password interval is terminated if power is disconnected.
9. If the password protection is enabled, the `Event History` can be reviewed after entering the correct password.

Event History

Information Logged

Up to 502 events can be logged and stored in the display unit in a rolling data set. Information stored includes:

- Event (trip fault, power interruption, etc)
- Time of event (pump run time)
- 3 motor currents
- 3 line voltages

Reviewing Events

- Before events can be reviewed, a valid password must be entered (if the password is other than 0 0 0).
- Each event is represented by one screen of information.
- Each event is numbered (0-511).
- Each event has a time stamp displayed in days (0-1165), hours (0-23), minutes (0.0-59.9). The time stamp displayed is the total pump run time.
- You can sequence through the events by turning the knob; CCW goes backward in time, CW goes forward in time.
- Entering the Event Review system is itself an event that is logged. This event provides the Total (pump) Run Time. This will be the first event shown upon entry into the Event History, and is identified as "Total Run Time".

Events Logged

- Total Run Time (always the most recent event)
- Power Up Delay (records power interruptions)
- Tripped : Underload
- Tripped : Overload
- Tripped : Unbalance
- Tripped : Overheat
- Tripped : Overvoltage
- Tripped : Undervoltage
- Tripped : FalseStart
- Manual Reset
- Protection Change (Trip Point, etc.) (New protection data recorded)
- Defaults Restored (New protection data recorded)
- Motor Change (Hz, Volt, SFA) (New motor data recorded)

When "detailed" logging mode is selected, every switch event and timed reset is recorded. This mode is typically used only for detailed system troubleshooting. Additional events logged:

- Timed Reset (Motor Start by SubMonitor)
- Switch On (Motor Start by External Control)
- Switch Off (Motor Stop by External Control)

Key to Parameters in Event History

Whenever a setting is changed in the menu, the change is recorded in the event history as a Parameter Change. The parameter that was changed is identified with a parameter number per the following table, and the new setting is recorded.

Parameter Number	Description
0	Motor Rated Frequency
1	Motor Rated Voltage
2	Motor SFA - hundreds digit
3	Motor SFA - tens digit
4	Motor SFA - ones digit
5	Motor SFA - tenths digit
7*	Trip Enable Flags
8*	Auto Restart Flags
9	Number of Underload Restarts
10	Number of Other Restarts
11	Time Between Starts
12	Power-Up Time Delay
13	Underload Trip Point
14	Timeout for Underload Trip
15	Overload Trip Point
16	Timeout for Overload Trip
17	Unbalance Trip Point
18	Timeout for Unbalance Trip
19	Timeout for Overheat Trip
20	Overvoltage Trip Point
21	Timeout for Overvoltage Trip
22	Undervoltage Trip Point
23	Timeout for Undervoltage Trip
24	Number of False Starts
25	Timeout for False Start Trip

* Flags are binary format (ie. 1101001) where 1=enabled; 0=disabled.
Order of flags: underload, overload, unbalance, overheat, overvoltage, undervoltage, false start.

For example, for flags 1101001:

Underload, overload, overheat, and false start trips are enabled.

Unbalance, overvoltage, and undervoltage trips are disabled.

SubMonitor

Other Features

Reset

The SubMonitor will not allow a reset for several minutes after a fault trip, depending on the programmed reset time and fault mode. This allows time for the motor to cool before it is restarted after a problem has occurred. Any Manual Reset causes the motor to restart in exactly one minute.

Operation without the Display Unit

After the **Select Motor** parameters are entered (volts, Hz, and SF Amps), the base unit of SubMonitor provides full motor protection even when the Display Unit is disconnected.

When operating with a Base Unit only:

- A “run enable” condition is indicated by a green LED
- A trip condition is indicated by a red Fault LED
- Manual reset is initiated by pressing the Reset Switch
- The Event History is not recorded (total run time is recorded).

Special Conditions

Note: The SubMonitor is **not** compatible with variable frequency drives, electronic phase converters, or solid state soft starters. These devices will cause nuisance tripping of the motor overload fault, or may cause damage to SubMonitor components.

Reduced voltage starters may be used with SubMonitor if they are bypassed during normal running condition (Figure 5), and if the starting time does not exceed 3 seconds.

Power Factor or Surge Capacitor— across-the-line capacitors for either power factor correction or surge protection may be used with SubMonitor. If used, these capacitors must be connected to the power supply lines before these lines pass through the SubMonitor sensor coil windows or motor overload protection may be lost.

Note: At installations where the line voltage is typically 100 to 110% of nominal, it may be necessary to increase the default underload trip setting to fully protect the system against underload conditions.

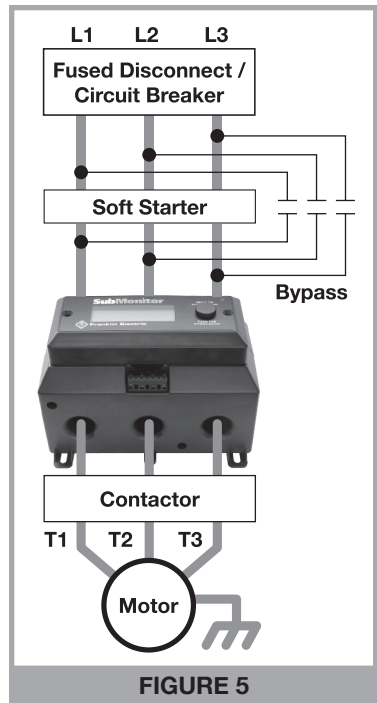

Programmable Options

	Trip Point Settings				Timeout Settings						
	Default Setting	Min	Max	Increment	Adjustable Range	Default Setting	Min	Max	Increment		
General Parameters											
Restart Attempts - Underload	On	3	0	10*	1	Restarts				minutes / seconds	
Restart Attempts - All Other	On	3	0	10*	1	Restarts					
Time Between Starts							1	0	10	1	min
Power Up Delay							30	10	120	10	sec
Specific Parameters											
Underload	On	75%	30%	100%	5%	of SFA	30	10	120	10	min
Overload	On	115%	80%	125%	5%	of SFA	10	5	60	5	min
Undervoltage	On	90%	80%	90%	2%	of Vrated	1	1	15	1	min
Overvoltage	On	110%	110%	120%	2%	of Vrated	1	1	15	1	min
Current Unbalance	On	5%	2%	10%	1%		10	5	60	5	min
Overheated Motor	On						10	5	60	5	min
False Start (Chattering)	On	10	3	15	1	starts in 10 sec.	1	1	15	1	min

* Unlimited restarts (***) may also be selected.

Troubleshooting

Fault Message	Problem / Conditions	Possible Cause
SF Amps Set Too High	SF Amps setting above 350 Amps	Motor SF Amps not entered
Phase Reversal	Reversed incoming voltage phase sequence	Incoming power problem
Overrange	Measured voltage or current is exceeding the selected motor settings	Wrong Motor Voltage or SFA Setting Excessively high line voltage or motor current
Underload	Normal line current	Wrong SF Max Amps setting
	Low line current	Over pumping well
		Clogged pump intake
		Closed valve
		Loose pump impeller
		Broken shaft or coupling
Phase loss		
Overload	Normal line current	Wrong SF Max Amps setting
	High line current	High or low line voltage
		Ground fault
		Pump or motor dragging
		Motor stalled or bound pump
Overheat	Motor temperature sensor has detected excess motor temperature	High or low line voltage
		Motor is overloaded
		Excessive current unbalance
		Poor motor cooling
		High water temperature
		Excessive electrical noise (VFD in close proximity)
Unbalance	Current difference between any two legs exceeds programmed setting	Phase loss
		Unbalanced power supply
		Open delta transformer
Overvoltage	Line voltage exceeds	Unstable power supply
Undervoltage	Line voltage below programmed setting	Poor connections in motor power circuit
		Unstable or weak power supply
False Starts	Power has been interrupted too many times in a 10 second period	Chattering contacts
		Loose connections in motor power circuit
		Arcing contacts

Maintenance

Symptom	Possible Cause or Solution
SubMonitor Dead	If the line voltage is correct at the SubMonitor's L1, L2 and L3 terminals and the display is blank, remove display and check cable connections. If cable connections are ok, then SubMonitor is malfunctioning.
SubMonitor's Screen Does Not Change from Franklin Electric Screen	Check for a broken or disconnected communications cable from base to display. If cable is ok, then SubMonitor is malfunctioning.
Display reads "Phase Reversal"	SubMonitor has a built-in phase sequence meter to assure once properly installed, a change in incoming power sequence cannot cause the pump to run backwards. If the display reads "Phase Reversal" the SubMonitor thinks the motor will run in the wrong direction.
	On a new installation, after verifying proper motor rotation, switch power leads L1 and L2 on top of the SubMonitor. DO NOT CHANGE THE MOTORS LEADS.
	On an old installation that was working fine, verify proper motor rotation and/or switch motor leads T1 and T2 at the starter as needed. DO NOT CHANGE THE SUBMONITOR POWER LEADS.
Tripped Light On	Whenever the pump is off as a result of SubMonitor protective function, the red tripped LED (light) on the display and base will turn on.
Control Circuit Fuse Blows	With power turned off, check for a shorted contractor coil or a grounded control circuit lead. The coil resistance should be at least 10 ohms and the circuit resistance to panel frame should be over 1 megohm. A standard or delay-type 1.5 Amp fuse should be used.
SubMonitor Contactor Will Not Close	If proper voltage is at the control coil terminals when controls are operated to turn the pump on, but the contactor does not close, turn off power and replace the coil. If there is no voltage at the coil, trace the control circuit to determine if the fault is in the fuse, wiring or panel operating switches. This tracing can be done by first connecting a voltmeter at the coil terminals and then moving the meter connections step by step along each circuit to the power source, to determine at which component the voltage is lost.
Contactor Hums or Chatters	Check that coil voltage is within 10% of rated voltage. If voltage is correct and matches line voltage, turn off power and remove the contactor magnetic assembly to check for wear, corrosion or dirt. If voltage is erratic or lower than line voltage, trace the control circuit for faults similar to the previous item, but looking for a major drop in voltage rather than its complete loss.
Contactor Opens When Start Switch is Released	Check that the small interlocks switch on the side of the contactor closes when the contactor closes. If the switch or circuit is open, the contactor will not stay closed when the selector switch is in HAND position.
Contactor Closes But Motor Doesn't Run	Turn off power. Check the contactor contacts for dirt, corrosion and proper closing when the contactor is closed by hand.

Specifications

Electrical

Input Voltage	3-Phase 190-600 VAC
Frequency	50 Hz or 60 Hz
Motor SF (Max) Amps Range	5 amps to 350 amps
Maximum Conductor Size Through Sensors	0.92" diameter, #0000 AWG Max 23 mm diameter, 95 mm ² gauge max
Measurement Accuracy *	
Voltage	1% ± 1 digit
Current	1% ± 1 digit
Trip Time - Locked rotor, underload, overload, overheat, unbalance, overvoltage, undervoltage	3 seconds
Input Current, L1, L2, L3	0.15 amps
Control Circuit Rating	1.5 amp AC, up to 600 volts
Signal Circuit Rating	1 amp AC, up to 250 volts Incandescent lamp, 100 watts max
Agency Approvals	UL 508 classification NKCR, NKCR7 file E160632 cUL
Standards Met	
Surge	ANSI/IEEE C62.41
Electrical Fast Transient	IEC 1000-4-4 Level 4, 4kV
ESD	IEC 1000-4-2 Level 3, 6kV

Mechanical

Dimensions (WxHxD)	
Base Unit	8.0" x 5.35" x 4.3" (20.3 x 13.6 x 10.9 cm)
Display Unit	7.0" x 3.0" x 1.4" (17.8 x 7.6 x 3.6 cm)
Total Unit	8.0" x 5.35" x 5.7" (20.3 x 13.6 x 14.5 cm)
Weight	
Base Unit	46 oz (1.3 kg)
Display Unit	7 oz (0.2 kg)
Total Unit	53 oz (1.5 kg)
Operating Temperature Range	-20 °C to +60 °C
Storage Temperature Range	-30 °C to +80 °C
Relative Humidity	10-95% non-condensing
Protection Class	
Display Unit	NEMA 3R
Base Unit	NEMA 1

* When Strong radio frequency energy is present, SubMonitor measurement accuracy (voltage and current) is ± 3%. Contact Franklin Electric technical support for assistance with these types of installations.

Mounting Dimensions

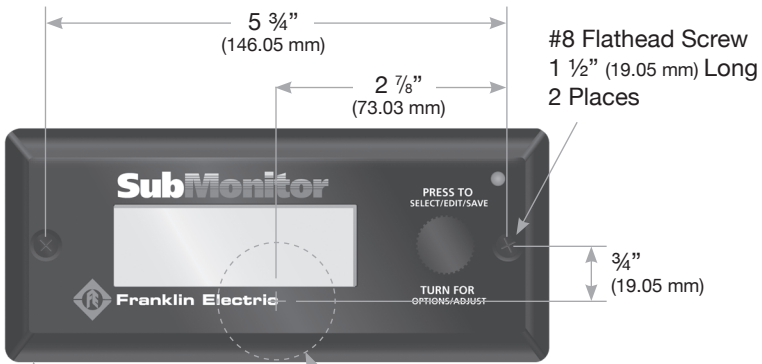
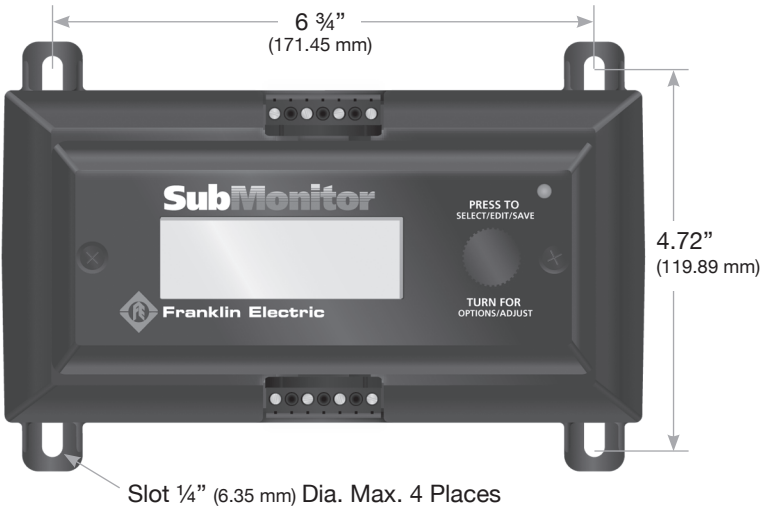

Install Gasket Between the Panel and the Back of the Display Unit

1 1/2" (19.05 mm) Dia. Clearance Hole in Control Panel Cover for RJ Cable

For Mounting Detachable Display Unit on the Cover of a Control Panel

SubMonitor

Notes

TOLL-FREE HELP FROM A FRIEND
Franklin Electric
Submersible Service Hotline
800-348-2420